

## hl 4/18/25

Scanhugger HL 4/18/25 is an all-round shredder, capable of shredding all types of woodwaste (solid wood, particleboard, MDF, pallets, cardboard, paper, demolition waste wood) depending on the material to be processed and the desired chip quality, the machine can be mounted with 2 different rotor types and various screen sizes.

Scanhugger HL 4/18/25 er en all-round træknuser, der er velegnet til knusning af alle typer træaffald (massivt træ, spånplade, MDF, paller, pap, papir, kartonageaffald). Afhængig af materialetype og ønsket flisstørrelse kan maskinen monteres med 2 rotortyper til henholdsvis fine/grove flistyper.



Rotor/knife  
Rotor/kniv



screen  
sold

### Technical data / Tekniske data.

Hopper dimension / Magasinmål		1758 x 2515 mm
Hopper volume / Magasinindhold		3,7 cbm
Rotor diameter / Rotor diameter		Ø 370 mm
No.of knives / Knivantal	*	50 / 32
No.of counterknives / Antal modstål		4
Rotor speed/ Rotoromdrejninger	**	80 - 100 <sup>-1</sup>
Main motor / Hovedmotor	**	55 - 90 kW
Screen perforation / Soldperforering	**	30 - 100 mm
Chip length / Flislængde	**	40 - 200 mm
Capacity / Kapacitet	**	1500-8000kg/60min
Weight / Vægt		9000 kg
Sound level / Lydtrykniveau L <sub>pa</sub>	***	86,5 dB

\* Depending on rotor and type of knife

\*\* Depending on motor size, material and screen perforation

\*\*\* In accordance with ISO/DIS 11204, prEN 691

Technical alterations reserved / Ret til tekniske ændringer forbeholdes

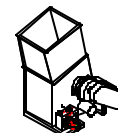

HL 2 SERIE

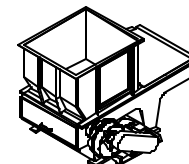

HL 3 SERIE

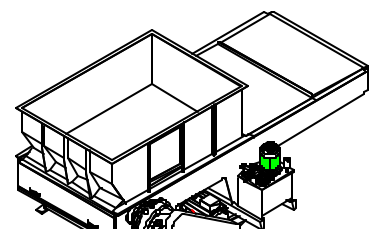

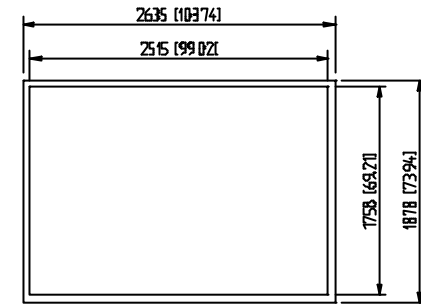
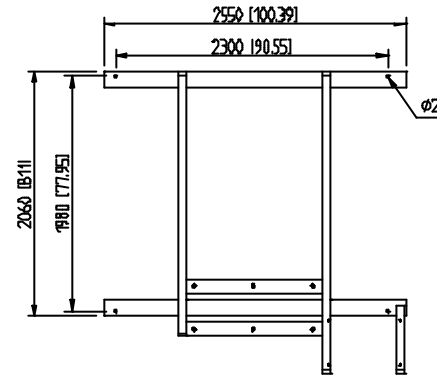
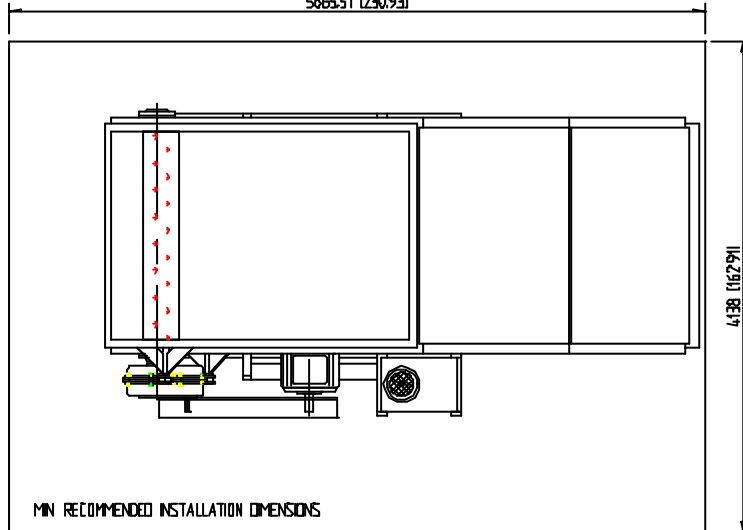
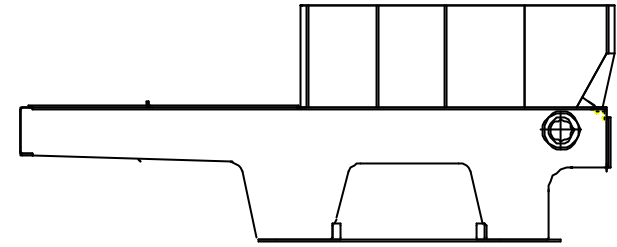
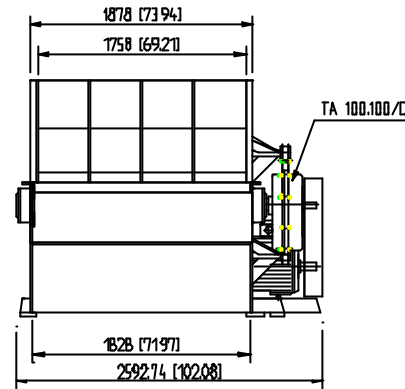
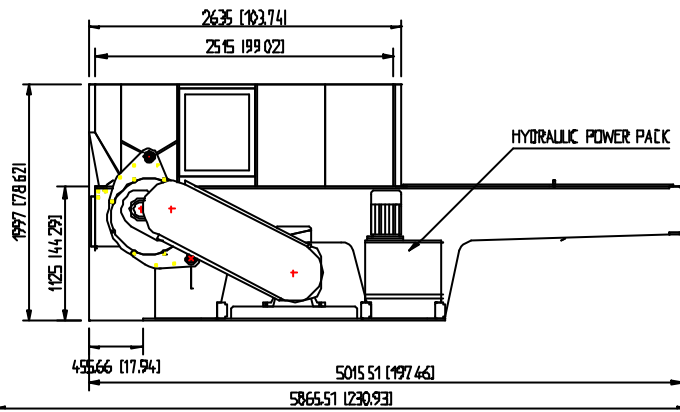

MAX. INSTALLATION HEIGHT/WIDTH UNDER GEARBOX

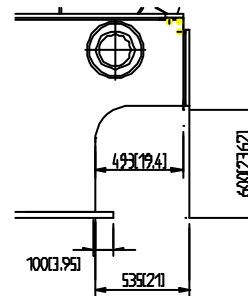
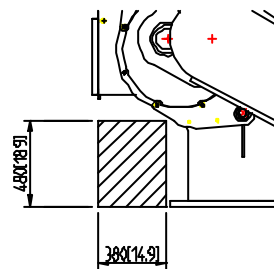

STANDARD CONFIGURATION WITH GEAR AND MOTOR MOUNTED ON LEFT SIDE  
ALL DIMENSIONS IN MM (INCHES)

MAIN MOTOR FRAME SIZE 55 - 90 KW  
HYDRAULIC MOTOR 75 KW  
CONTROL POWER  
SCREEN PERFORATION 20-80 MM  
CHIP TRANSPORT SYSTEM DISCHARGE SCREW/CONVEYOR

ALL DIMENSIONS ARE APPROXIMATE

Project	Mod	Ben/Ver/Doc	Formal	Scale	Bar/Printing
Name	Sign				Created at
		Title		PL Date	
<b>HEDETR? A/S</b> <small>DK 4600 SØNDERSBO            TEL: +45 70 22 10 00            FAX: +45 70 22 10 01</small>		<small>After signing of P. Also license after P. copies under P. file given by/for the for/department            The drawing is not to be copied, printed or to be available to any unauthorized person without our            explicit permission</small>		Prepared by Date	